

WRL SEALED LOCK SWITCHES

GENERAL ELECTRICAL & MECHANICAL SPECIFICATION

Switch Rating:	5A @ 115Vac
(Switching Resistive load):	3A @ 50Vdc
Life:	>10,000 Cycles
Operating Temperature:	-20°C to +65 °C
Proof Voltage:	750 Vdc (Initial)
Insulation Resistance:	>999 MΩ at 500Vdc (Initial)
Contact Resistance:	<20 mΩ (Initial)
Lock Type:	5 Disc
Std. Qty. of Keys per Lock:	2 Brass - Ni Plated
Contact Material:	Brass CZ108 Ag Plated
Moulding Material:	Polyamide 6.6 UL94V0 Rated
Lock Housing:	Zinc Alloy Bright Cr Plated

RoHS COMPLIANT



IP66 / IP67 RATED

GENERAL FEATURES

- Made in UK.
- Miniature key-operated Lock switch.
- Single or Double pole
- Up to 200 key combinations – keys to differ.
- Common keys available – keys to pass.
- Keys are double entry (they can be inserted into the lock either way up).
- Occupies small panel area.
- Easily assembled through front of equipment panel.
- Rear projection less than 30mm from panel.
- M16 Earthing tag available as an optional extra.
- For continued exterior use lubricate with oil regularly
- Suitable for Marine Environment exposure to Severity 1(EN60068-2-52)

DOUBLE POLE LOCK SWITCH

Tapered Lock Head 60° Indexing

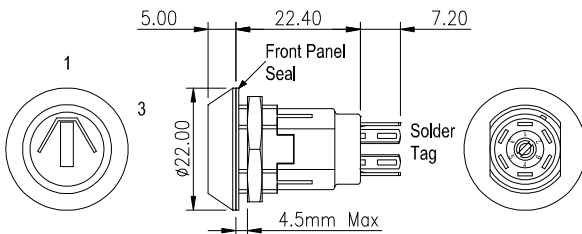

Key Withdrawal Positions

SEVERITY ONE

SALT MIST CYCLE TESTED

BASIC PART No.	TOTAL MOVEMENT	INDEXING	KEY WITHDRAWAL POSITIONS	SWITCH CONFIGURATION
WRL-5-L	60°	60°	1,3	
WRL-5-M	60°	60°	1 ONLY	

SINGLE POLE LOCK SWITCH

Tapered Lock Head 90° Indexing

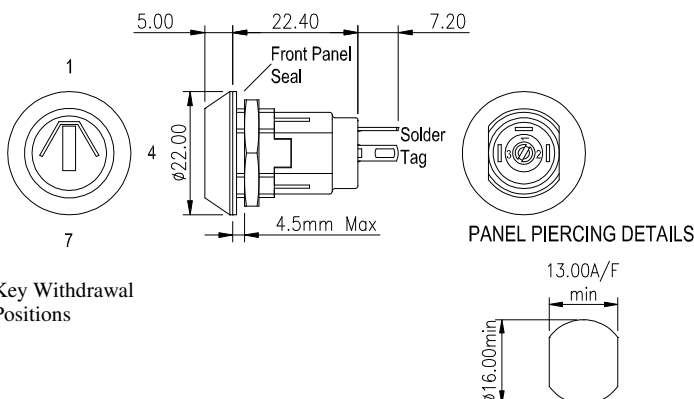

Key Withdrawal Positions

BASIC PART No.	TOTAL MOVEMENT	INDEXING	KEY WITHDRAWAL POSITIONS	SWITCH CONFIGURATION
WRL-5-D	90°	90°	1,4	
WRL-5-E	90°	90°	1 ONLY	
WRL-5-F	180°	90°	1,4,7	
WRL-5-P	180°	90°	1,4,7	

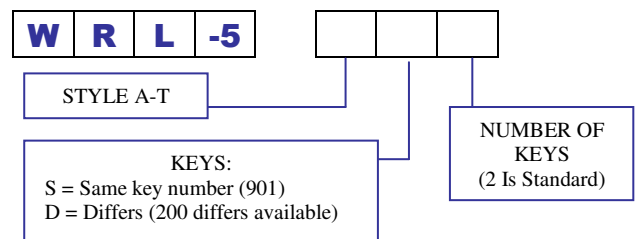

WRL LOCK SWITCH CODE